



SRT/SFT Flat Bed Tractors

- Tracked and rubber undercarriage
- Welding, pipe carrying, induction heating, dumping and sand-blasting configurations



SRT/SFT FLAT BED TRACTORS

MODULAR DESIGN

SUPERIOR's wide range of flat bed tractors were especially designed for heavy duty working conditions.

There are two basic lines available: rubber undercarriage, for increased speed and ease of movement and tracked undercarriage, for better traction and higher weight loads. All the models feature a hydrostatic transmission.

These tractors are highly customizable to better suit our customers' specific needs: hydraulic booms for welding tents, workshop boxes, dumpers, pipe carrying kits, etc.

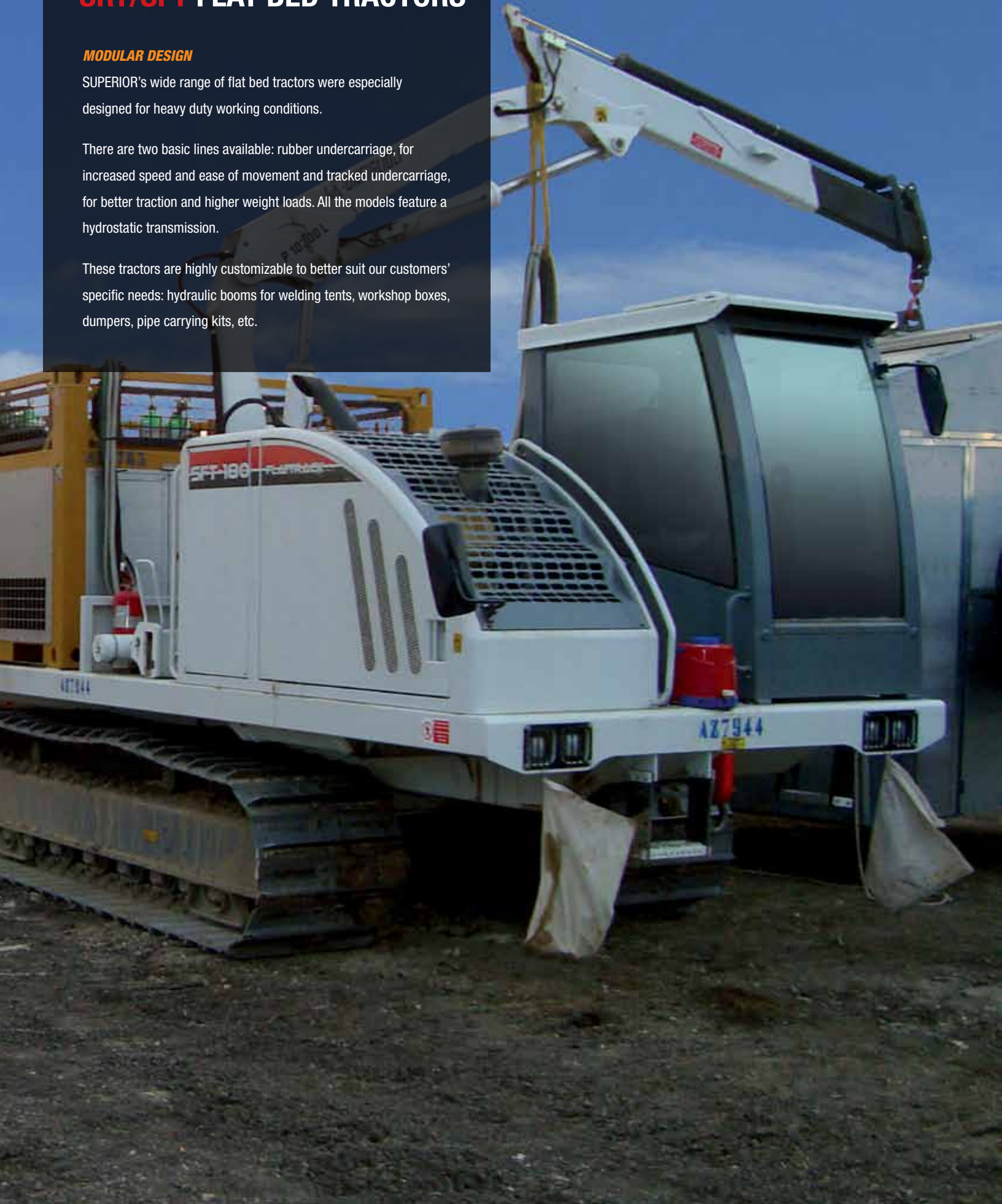

DIMENSIONS

RUBBER UNDERCARRIAGE

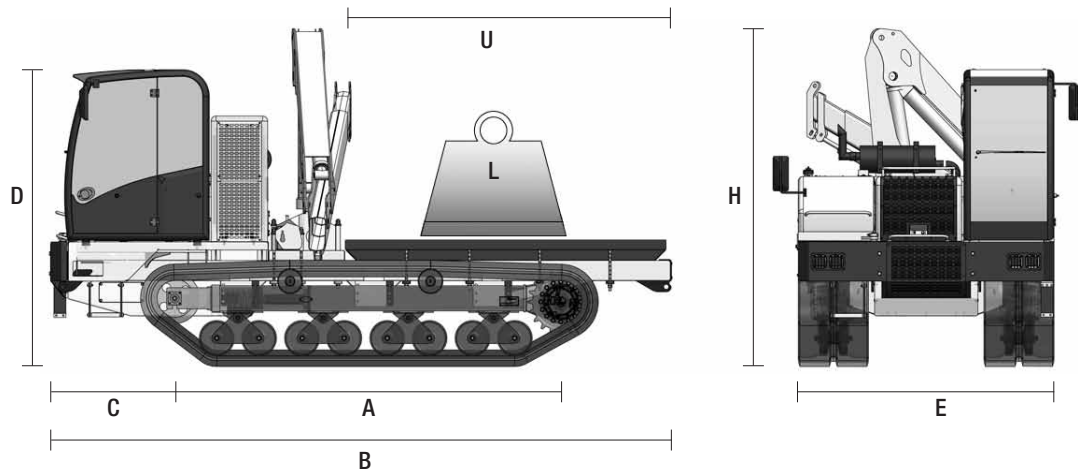

	A	B	C	D	E	H	L	U
SRT-155FB	12.6 ft / 3,85 m	20.3 ft / 6,2 m	4 ft / 1,24 m	9.7 ft / 2,95 m	8.4 ft / 2,55 m	11 ft / 3,36 m	13,228 lb / 6000 kg	10.5 ft / 3,2 m
SRT-155WS	12.6 ft / 3,85 m	20.3 ft / 6,2 m	4 ft / 1,24 m	9.7 ft / 2,95 m	8.4 ft / 2,55 m	-	13,228 lb / 6000 kg	13.1 ft / 4 m
SRT-155DP	12.6 ft / 3,85 m	18.8 ft / 5,74 m	4 ft / 1,24 m	9.7 ft / 2,95 m	8.4 ft / 2,55 m	-	95.35 ft ³ / 2.7 m ³ *	-

* MAX CAPACITY

TRACKED UNDERCARRIAGE

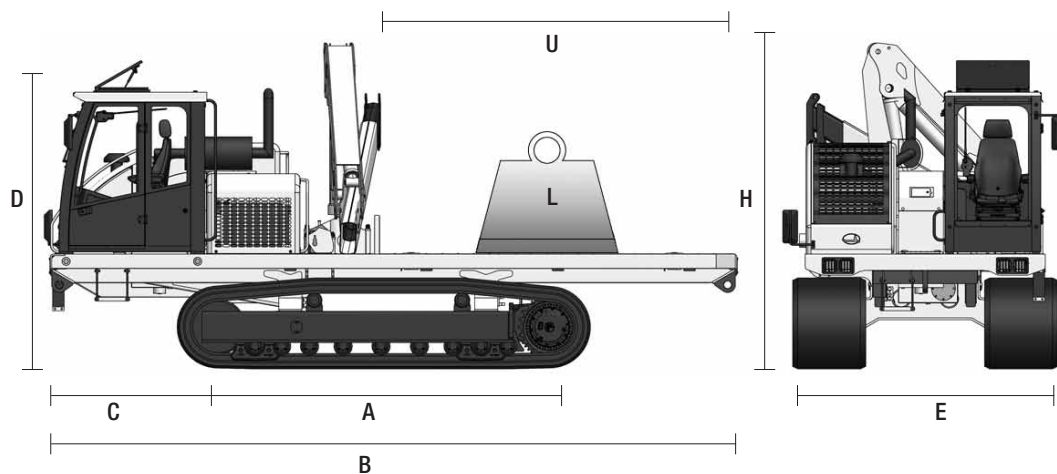

	A	B	C	D	E	H	L	U
SFT-155	4.1 ft / 1,25 m	18.7 ft / 5,7 m	10.8 ft / 3,3 m	9.7 ft / 2,95 m	8.4 ft / 2,55 m	-	11,023 lb / 5000 kg	10.5 ft / 3,2 m
SFT-180	11.3 ft / 3,45 m	23.5 ft / 7,15 m	5.75 ft / 1,75 m	9.7 ft / 2,95 m	9 ft / 2,76 m	11.5 ft / 3,49 m	22,046 lb / 10000 kg	12.2 ft / 3,72 m
SFT-180W	11.3 ft / 3,45 m	24.1 ft / 7,35 m	5.75 ft / 1,75 m	9.7 ft / 2,95 m	9 ft / 2,76 m	11.5 ft / 3,49 m	22,046 lb / 10000 kg	-
SFT-225D	12 ft / 3,67 m	19.5 ft / 5,95 m	5.5 ft / 1,67 m	9.85 ft / 3 m	8.4 ft / 2,55 m	-	247 ft ³ / 7 m ³ *	-
SFT-250	12 ft / 3,66 m	23 ft / 7,04 m	5.5 ft / 1,69 m	10 ft / 3,06 m	9.7 ft / 2,95 m	11.6 ft / 3,52 m	26,455 lb / 12000 kg	9.3 ft / 2,82 m

* MAX CAPACITY



TRACKED UNDERCARRIAGE



SFT-155

- **HORSEPOWER:**
175 HP @ 2200 RPM
- **WEIGHT:**
10500 KG
- **HYDRAULIC BOOM SIZE:**
7 TM
- **LOAD CAPACITY:**
5000 KG
- **MAXIMUM SPEED:**
7 KM/H



SFT-225D

- **HORSEPOWER:**
225 HP @ 2200 RPM
- **WEIGHT:**
17000 KG
- **CAPACITY:**
15 M3
- **MAXIMUM SPEED:**
5 KM/H



SFT-180

- **HORSEPOWER:**
205 HP @ 2200 RPM
- **WEIGHT:**
13500 KG
- **HYDRAULIC BOOM SIZE:**
10 TM
- **LOAD CAPACITY:**
6000 KG
- **MAXIMUM SPEED:**
5 KM/H



SFT-250

- **HORSEPOWER:**
205 HP @ 2200 RPM
- **WEIGHT:**
17000 KG
- **HYDRAULIC BOOM SIZE:**
13 TM
- **MAXIMUM SPEED:**
7.7 KM/H



SFT-180W

- **HORSEPOWER:**
225 HP @ 2200 RPM
- **WEIGHT:**
18500 KG
- **HYDRAULIC BOOM SIZE:**
10 TM
- **GENERATOR:**
150 KVA
- **MAXIMUM SPEED:**
5 KM/H

MODELS & BASE CONFIGURATIONS



RUBBER UNDERCARRIAGE



SRT-155 WS

- **HORSEPOWER:**
175 HP @ 2200 RPM
- **WEIGHT:**
9500 KG
- **LOAD CAPACITY:**
6000 KG
- **MAXIMUM SPEED:**
7.4 KM/H



SRT-155 FB

- **HORSEPOWER:**
175 HP @ 2200 RPM
- **WEIGHT:**
11500 KG
- **HYDRAULIC BOOM SIZE:**
10 TM
- **FLAT BED:**
3200 MM X 2550 MM
- **MAXIMUM SPEED:**
7.4 KM/H



SRT-155 DP

- **HORSEPOWER:**
175 HP @ 2200 RPM
- **WEIGHT:**
11500 KG
- **CAPACITY:**
2,7 M3
- **MAXIMUM SPEED:**
7.4 KM/H

TOP QUALITY COMPONENTS



Joystick Control

The ergonomic joystick controller can be hydraulic or electronic, and provides better control of the machine. The hydrostatic transmission high reliability is due to its components: Sauer-Danfoss or Bosch-Rexroth.



Engines

You have a choice of engine: Caterpillar or Iveco FPT. Both of these comply with environmental rules (Epa and Tier 4.)





Hydraulic Boom

We have several brands of hydraulic booms from which to choose: Hiab, Maxilift or Bonfiglioli.



Configurations

The SRT/SFT Series modular design makes it highly customizable: it can be configured as a welding tractor, pipe carrier (shown above), dump tractor (insert), sand-blasting or induction heating tractors.

AVAILABLE MODELS

CONTACT INFORMATION



Rubber Undercarriage

SRT-155 WS
SRT-155 FB
SRT-155 DP



Tracked Undercarriage

SFT-155
SFT-180
SFT-180W
SFT-225D
SFT-250

Europe

Phone +49.0.231.963.3073
pipelinece@wwmach.com

Russia, China and the Middle East

Phone +39.349.198.1281 Italy
Phone +7.495.507.4827 Russia
fsupipeline@wwmach.com

India

Phone +91.11.414.59230
pipelineind@wwmach.com

Africa

Intl. Toll Free 800.9675.3948
pipeline@wwmach.com

North America

Phone +1.281.457.4400
pipelinena@wwmach.com

Latin America

Phone +52.81.8.394.0160
pipelinesa@wwmach.com

Brazil

Phone 800.9675.3948
pipelinebr@wwmach.com

Australia

Phone +61.0.400.144.432
pipelinece@wwmach.com

All information is subject to change without notice.



16031 East Freeway
Houston, TX 77530
Phone 281.457.4400 Fax 281.452.5455
U.S. Toll Free 800.383.2666 Intl. Toll Free 800.9675.3948
pipeline@wwmach.com
www.worldwidemachinery.com