



## SPB 22-36 Pipe Bending Machine

Operating weight	59,525 lbs / 27,000 kg
Max. Operating Pressure	4,350 p.s.i. / 300 bar
Horsepower	99.5 HP (with Cat engine)



# SPB 22-36 PIPE BENDER

## ABOUT THE SPB 22-36

The new pipe bending machine SPB 22-36 belongs to the "Millennium Series" fleet, which is the new generation of SUPERIOR pipe benders. Despite its simplicity, this machine guarantees high performance in terms of speed and push.

The hydraulic system has 5 spools; the fifth spool may be used to control the hydraulic mandrel, if fitted. The separate valves enable the operator to set the mandrel pressure independently from the machine. The hydraulic cylinders are sized in such a way that they can operate with pressures exceeding 300 bar.

The SPB 22-36 is installed on tilting idle tracks. Its dimensions and low profile make its travel easy on any job site. The Caterpillar chains are equipped with three bar shoes, the rollers are life-long lubrication type, and the track tensioning device is greased type. All these elements guarantee maximum machine reliability and life over time.

On request, LGP tracks are available. These are longer and have larger shoes to operate on soft soils where low specific pressure on the ground is required.

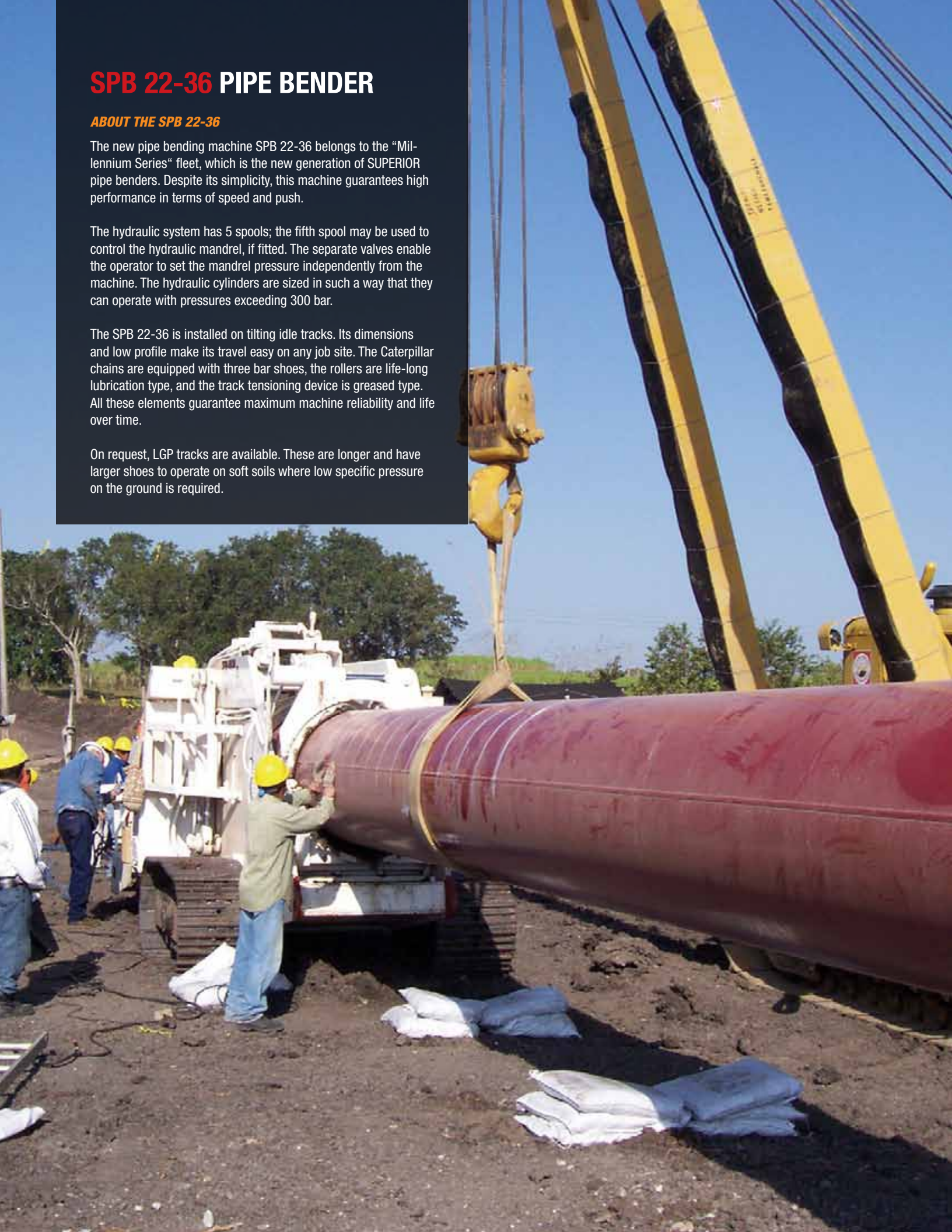

# SPECIFICATIONS

## ENGINE

Model	Caterpillar C-4.4 ACERT
Net flywheel power (DIN 6271)	99.5 HP
Governed speed	2,000 rpm
Displacement	4.01 liters
Number of cylinders	4
Sound proofing type	Yes

## HYDRAULIC PUMP

Type	Variable axial piston pump, with load-sensing and constant power control
Maximum flow rate	74 U.S. gal/min - 280 lt/min
Maximum constant pressure	5,046 p.s.i. / 350 bar
Maximum peak pressure	5,801 p.s.i. / 400 bar

## CONTROL VALVE

Brand	Rexroth
Type	Load-sensing with proportional control (LUDV)
Spools	N.5

## HYDRAULIC WINCH

Type	Hydraulic winch
Maximum pull at first layer	17,637 lbs / 8,000 kg
Hydraulic motor	Orbital DANFOSS
Frame	Aluminum allow + ductile cast iron
Reduction gear	With worm screw, irreversible
Neutral	Manual
Maximum operating pressure	1,885 p.s.i. / 130 bar
Maximum feed flow rate	26 U.S. gal/min - 100 lt/min
Speed at first layer	16 ft/min - 4,85 m/min
Recommended cable diameter	3/4 inch / Ø 16 mm
Wire rope type	6 strands with textile core R=2,160 N/mm <sup>2</sup> min. breaking load guaranteed 30,000 kg

## HYDRAULIC OIL TANK

Type	Metal work with filter
Capacity	68 U.S. gal / 260 lt
Cartridge type	Donaldson

## FUEL TANK

Type	Metal work with filter
Capacity	52 U.S. gal / 200 lt

## SPOOLS

### *Spool 1: Out-board and in-board cylinders, clamp*

Maximum flow	74 U.S. gal/min - 280 lt/min
Pressure	4,351 p.s.i. / 300 bar

### *Spool 2: Wedge cylinder*

Maximum flow	74 U.S. gal/min - 280 lt/min
Pressure	2,175-4,351 p.s.i. / 150-300 <sup>1</sup> bar

### *Spool 3: Winch*

Maximum flow	42.2 U.S. gal/min - 160 lt/min
Pressure	2,320 p.s.i. / 160 bar

### *Spool 4: Auxiliary control 1*

Maximum flow	26.4 U.S. gal/min - 100 lt/min
Pressure	2,320 p.s.i. / 160 <sup>2</sup> bar

### *Spool 5: Auxiliary control 2*

Maximum flow	26.4 U.S. gal/min - 100 lt/min
Pressure	1,740 p.s.i. / 140 <sup>2</sup> bar

<sup>1</sup> Cylinder out / in pressure

<sup>2</sup> Adjustable

# FEATURES



## ENGINE

A choice of Caterpillar, Perkins, Deutz and Cummins diesel engines, all of which have many reliable and modern features, such as the water pump, integrated filtration system, and self-stretching fan towing seals.

The engine is enclosed in a sound reducing box and is located on the side opposite the operator.

It also complies with recent anti-pollution requirements in all of the industrialized nations. The engine compartment is cleverly designed to swing open to allow easier access to the engine for maintenance.

## OPERATOR'S PLATFORM

The position of the piloting platform and the engine compartment on opposite sides make this machine unique in terms of operating comfort and guarantee maximum visibility and low noise levels to the operator.



## HYDRAULIC SYSTEM

New operator friendly hydraulic system with a load-sensing variable pump and a five-spool proportional valve, allowing much safer, faster and more precise control of movements. The new valve which was only recently introduced to the market allows the regulation of the pressure and the capacity of each function according to its purpose.

The three largest machines have an automatic power controlling system allowing a quick approach and a progressive slowing down when close to the maximum push. The hydraulic system features high quality components manufactured by Mannesmann Rexroth or Parker-Voac. All these components contribute to higher productivity and a reduction in power consumption.

The Millennium Series also has stronger hydraulic cylinders that have been tested to work at high pressures. The cylinders have molybdenum chromium-plated steel piston rods with components made to bear high pressure to 6,000 PSI.



### HYDRAULIC WINCHES

The hydraulic winches have a pulling capacity ranging from 3,000 to 10,000 Kg. The free drum control is located in the control panel on the operator's platform.



### TRACKS

Caterpillar-type crawler undercarriages with triple grouser bars on industrial-grade shoes. A hydraulic cylinder controls the tensioning of the tracks, as on all earth-moving tractors.

### ROLLERS

Pipe drive rollers are mounted on non-friction bearing and coated with 90 SH polyurethane for smoother handling of the pipe.

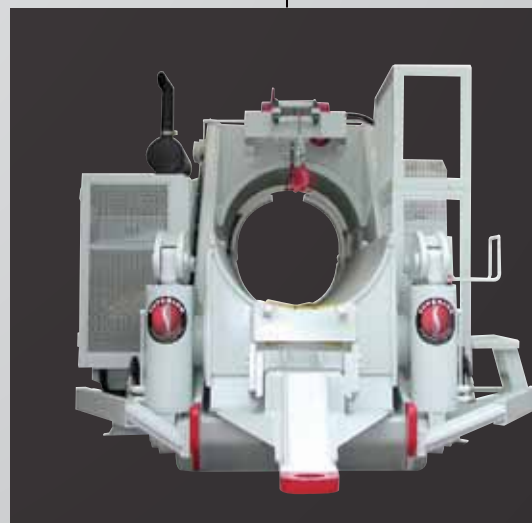

### FRAME

The main frame is built with high quality steel plate and box-section design. This makes the machine stronger and more resistant to stresses, thus permitting bending of pipes with very high tensile strength.



## BENDING DATA

### U.S.

Pipe O.D. inch	Maximum Wall Thickness By Grade (Inch)							Recommended Bend		
	X52	X56	X60	X65	X70	X80	X100	Degree per Arc Foot	Radius Feet	Max Degree Per 40 Feet
22	2	2	2	2	2	1-7/8	1-7/16	0.80	72	21.60
24	2	2	2	1-15/16	1-3/4	1-1/2	1-1/8	0.75	76	20.30
26	2	1-13/16	1-11/16	1-9/16	1-3/8	1-3/16	15/16	0.70	82	18.90
28	1-5/8	1-1/2	1-3/8	1-1/4	1-1/8	1	3/4	0.65	88	17.60
30	1-3/8	1-1/4	1-1/8	1-1/16	15/16	13/16	5/8	0.60	95	16.20
32	1-3/16	1-1/16	1	15/16	13/16	11/16	9/16	0.58	98	15.60
34	1	15/16	7/8	13/16	3/4	5/8	1/2	0.55	104	14.80
36	7/8	13/16	3/4	11/16	5/8	9/16	7/16	0.50	115	13.50

### METRIC

Pipe O.D. inch/mm	Maximum Wall Thickness By Grade (Inch)							Recommended Bend		
	X52	X56	X60	X65	X70	X80	X100	Ratio Radius: O.D.	Radius Meter	Max Degree Per 12 Meters
22 / 558.8	50.80	50.80	50.80	50.80	50.80	47.63	36.52	39.3	21.95	21.60
24 / 609.6	50.80	50.80	50.80	49.22	44.45	38.10	28.58	38.0	23.16	20.30
26 / 660.4	50.80	46.04	42.87	39.69	34.93	30.17	23.82	37.9	24.99	18.90
28 / 711.2	41.28	38.10	34.93	31.75	28.58	25.40	19.05	37.7	26.82	17.60
30 / 762	34.93	31.75	28.58	26.99	23.82	20.64	15.88	38.0	28.96	16.20
32 / 812.8	30.17	26.99	25.40	23.82	20.64	17.47	14.29	36.7	29.87	15.60
34 / 863.6	25.40	23.82	22.23	20.64	19.05	15.88	12.70	36.7	31.70	14.80
36 / 914.4	22.23	20.64	19.05	17.47	15.88	14.29	11.12	38.3	35.05	13.50

# DIMENSIONS

Operating weight 59,525 lbs / 27,000 kg

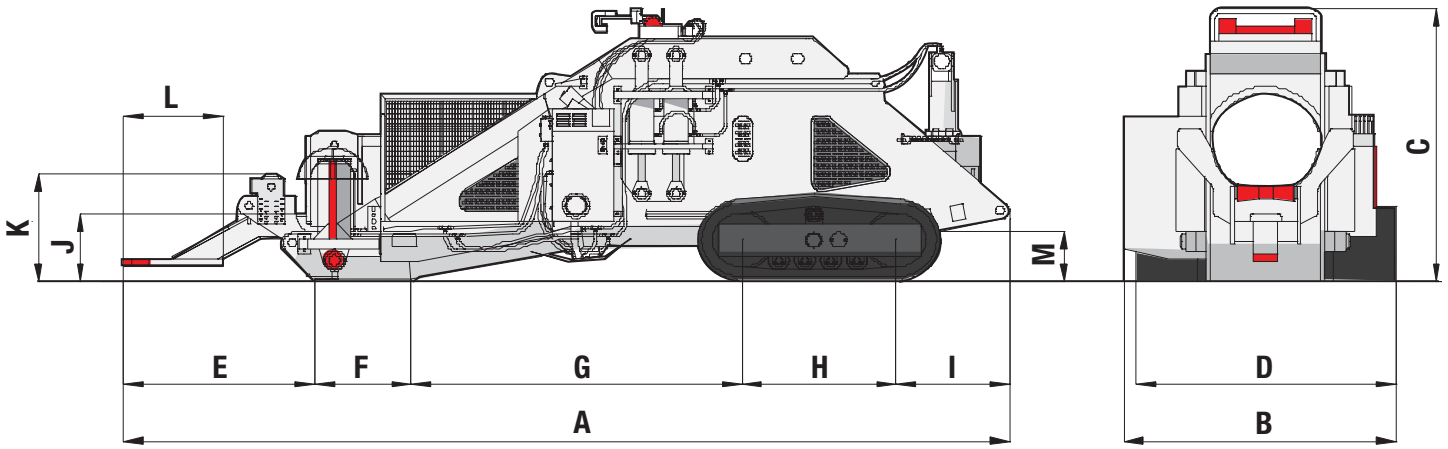

	Feet	Meters
A Overall length	26.25 ft	8 m
B Overall width	8.2 ft	2.5 m
C Height	9.4 ft	2.86 m
D Width to outside of tracks	8.1 ft	2.48 m
E Length of front section	5.7 ft	1.73 m
F Length of undercarriage touching the ground	2.8 ft	86.5 cm
G Length of middle section	9.8 ft	2.99 m
H Length of track on the ground	4.6 ft	1.4 m
I Length of rear section	3.4 ft	1.04 m
J Height to bottom of cradle	2.3 ft	70 cm
K Height to top of roller	3.6 ft	1.1 m
L Length of hitch	2.96 ft	90 cm
M Ground clearance	1.7 ft	51 cm

Track weight (loose pair) 7,111 lbs / 3,200 kg

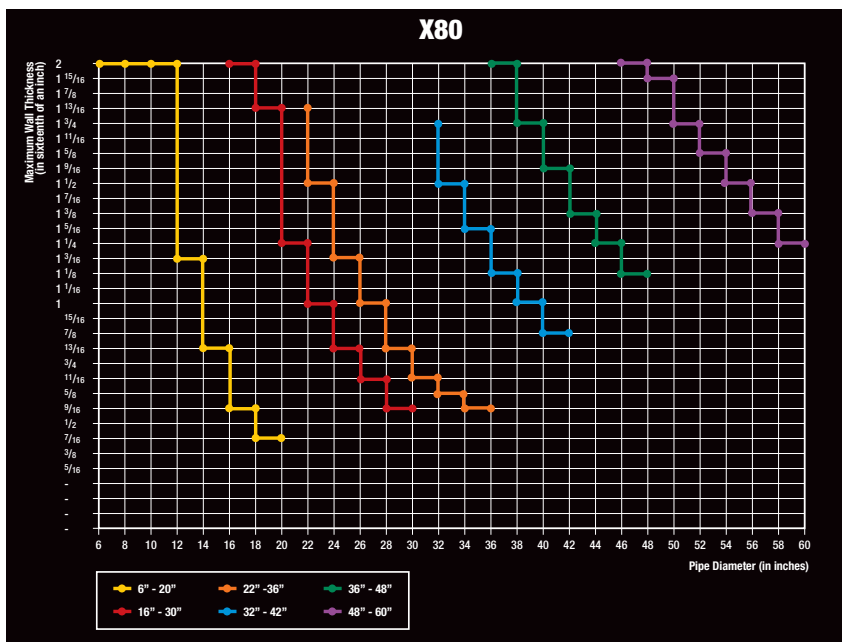

## BENDING STRENGTH

Here's an example of our pipe bending machines high bending strength. The bending performance data shown was calculated using **API X80** as an example. The machine is capable of bending all grades of currently available API-5L pipe within its range.



## AVAILABLE MODELS



SPB 6-20 Millennium Series



SPB 16-30 Millennium Series



SPB 22-36 Millennium Series



SPB 32-42 Millennium Series



SPB 36-48 Millennium Series



SPB 48-60 Millennium Series

## CONTACT INFORMATION

### Europe

Phone +49.0.231.963.3073

[pipelinece@wwmach.com](mailto:pipelinece@wwmach.com)

### Russia, China and the Middle East

Phone +39.349.198.1281 Italy

Phone +7.495.507.4827 Russia

[fsupipeline@wwmach.com](mailto:fsupipeline@wwmach.com)

### India

Phone +91.11.414.59230

[pipelineind@wwmach.com](mailto:pipelineind@wwmach.com)

### Africa

Intl. Toll Free 800.9675.3948

[pipeline@wwmach.com](mailto:pipeline@wwmach.com)

### North America

Phone +1.281.457.4400

[pipelinena@wwmach.com](mailto:pipelinena@wwmach.com)

### Latin America

Phone +52.81.8.394.0160

[pipelinesa@wwmach.com](mailto:pipelinesa@wwmach.com)

### Brazil

Phone 800.9675.3948

[pipelinebr@wwmach.com](mailto:pipelinebr@wwmach.com)

### Australia

Phone +61.0.400.144.432

[pipelinece@wwmach.com](mailto:pipelinece@wwmach.com)



16031 East Freeway

Houston, TX 77530

Phone 281.457.4400 Fax 281.452.5455

U.S. Toll Free 800.383.2666 Intl. Toll Free 800.9675.3948

[pipeline@wwmach.com](mailto:pipeline@wwmach.com)

[www.worldwidemachinery.com](http://www.worldwidemachinery.com)