



SPB 32-42 Pipe Bending Machine

Operating weight	95,900 lbs / 43,500 kg
Max. Operating Pressure	320 bar
Horsepower	225 HP / 168 kW



SPB 32-42 PIPE BENDER

ABOUT THE SPB 32-42

The new pipe bending machine SPB 32-42 belongs to the "Millennium Series" fleet, which is the new generation of SUPERIOR pipe benders. Despite its simplicity, this machine guarantees high performances in terms of speed and push.

The hydraulic system has 5 spools; the fifth spool may be used to control the hydraulic mandrel, if fitted. The separate valves enable the operator to set the mandrel pressure independently from the machine. The hydraulic cylinders are sized in such a way that they can operate with pressures exceeding 300 bar.

The system design and the proportional valves offer excellent modularity and sensitivity of machine movements, at the same time making the machine speed and push very easy to control.

The new position of the piloting platform and the engine compartment on opposite sides make this machine unique in terms of operating comfort and guarantee maximum visibility and low noise levels to the operator.

The SPB 32-42 is installed on tilting idle tracks. Its dimensions and low profile make its travel easy on any job site. The Caterpillar chains are equipped with three bar shoes, the rollers are life-long lubrication type, and the track tensioning device is greased type. All these elements guarantee maximum machine reliability and life over time.

On request, LGP tracks are available. These are longer and have larger shoes to operate on soft soils where low specific pressure on the ground is required.



SPECIFICATIONS

ENGINE

Model	Caterpillar C-6.6 ACERT
Net flywheel power (DIN 6271)	225 HP / 168 kW
Governed speed	1,900 rpm
Displacement	6.6 liters
Compression ratio	16:1
Engine bore	105 mm - 127 mm
Number of cylinders	6

HYDRAULIC PUMP

Type	Axial piston, load-sensing pump, with tilted plate and constant power control
Maximum flow rate	108 U.S. gal/min - 410 lt/min
Maximum constant pressure	127 U.S. gal/min - 483 lt/min
Maximum peak pressure	320 bar

CONTROL VALVE

Brand	Rexroth
Type	Load-sensing with proportional control (LUDV)
Spools	N.5

HYDRAULIC WINCH

Type	2.280.0017
Maximum pull at first layer	17,306 lbs / 7,850 kg
Hydraulic motor	Orbital DANFOSS
Frame	Aluminum allow + ductile cast iron
Reduction gear	With worm screw, irreversible
Neutral	Manual
Maximum operating pressure	1,885 p.s.i. / 130 bar
Maximum feed flow rate	26 U.S. gal/min - 100 lt/min
Speed at first layer	16 ft/min - 4,85 m/min
Recommended cable diameter	1/2 inch / Ø 13 mm
Wire rope type	6 strands with textile core
	R=2,160 N/mm ² min. breaking load guaranteed 15,700 kg

HYDRAULIC OIL TANK

Type	Metal work with filter
Capacity	121 U.S. gal / 460 lt
Cartridge type	Parker

FUEL TANK

Type	Metal work with filter
Capacity	76 U.S. gal / 290 lt

SPOOLS

Spool 1: Out-board and in-board cylinders, clamp

Maximum flow	84.5 U.S. gal/min - 320 lt/min
Pressure	4,641 p.s.i. / 320 bar

Spool 2: Wedge cylinder

Maximum flow	84.5 U.S. gal/min - 320 lt/min
Pressure	2,175-3,190 p.s.i. / 150-220 ¹ bar

Spool 3: Winch

Maximum flow	42.2 U.S. gal/min - 160 lt/min
Pressure	1,990 p.s.i. / 140 bar

Spool 4: Auxiliary control 1

Maximum flow	42.2 U.S. gal/min - 160 lt/min
Pressure	1,740 p.s.i. / 120 ² bar

Spool 5: Auxiliary control 2

Maximum flow	42.2 U.S. gal/min - 160 lt/min
Pressure	1,740 p.s.i. / 120 ² bar

¹ Cylinder out / in pressure

² Adjustable

FEATURES



ENGINE (Not shown)

A choice of Caterpillar, Perkins, Deutz and Cummins diesel engines, all of which have many reliable and modern features, such as the water pump, integrated filtration system, and self-stretching fan towing seals.

The engine is enclosed in a sound reducing box and is located on the side opposite the operator.

It also complies with recent anti-pollution requirements in all of the industrialized nations. The engine compartment is cleverly designed to swing open to allow easier access to the engine for maintenance.

OPERATOR'S PLATFORM

The position of the piloting platform and the engine compartment on opposite sides make this machine unique in terms of operating comfort and guarantee maximum visibility and low noise levels to the operator.

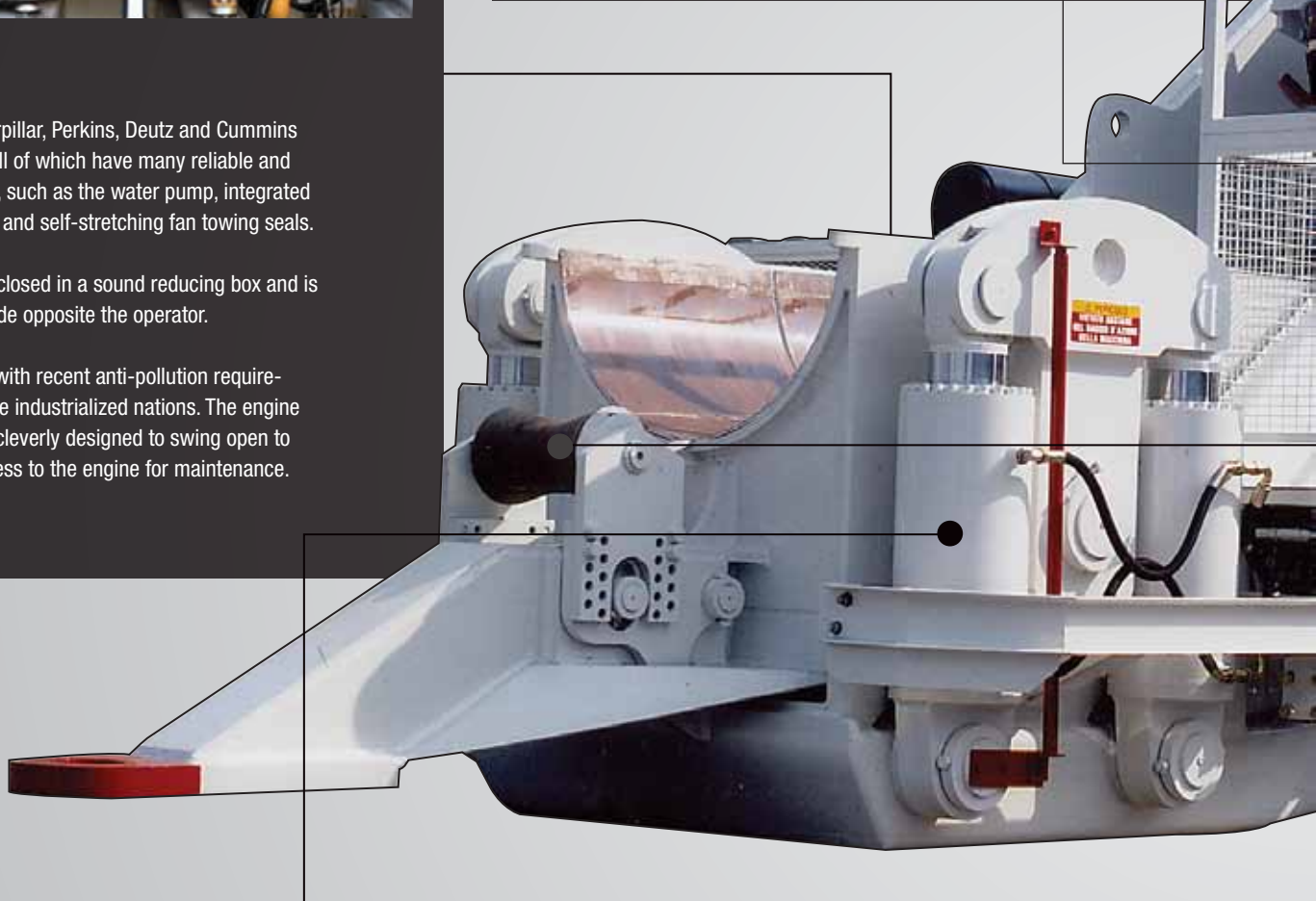

HYDRAULIC SYSTEM

New operator friendly hydraulic system with a load-sensing variable pump and a five-spool proportional valve, allowing much safer, faster and more precise control of movements. The new valve which was only recently introduced to the market allows the regulation of the pressure and the capacity of each function according to its purpose.

The three largest machines have an automatic power controlling system allowing a quick approach and a progressive slowing down when close to the maximum push. The hydraulic system features high quality components manufactured by Mannesmann Rexroth or Parker-Voac. All these components contribute to higher productivity and a reduction in power consumption.

The Millennium Series also has stronger hydraulic cylinders that have been tested to work at high pressures. The cylinders have molybdenum chromium-plated steel piston rods with components made to bear high pressure to 6,000 PSI.

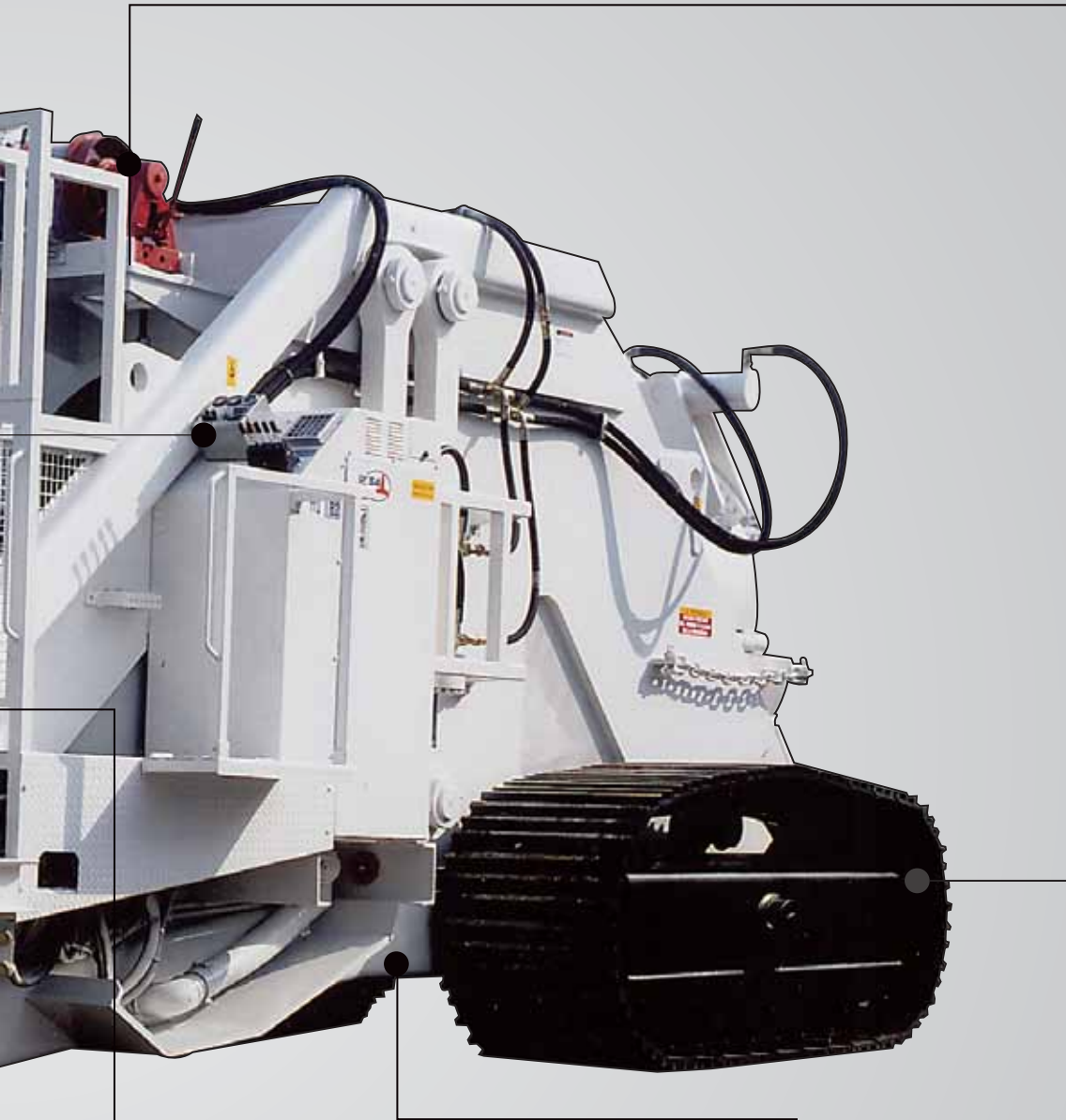

HYDRAULIC WINCHES

The hydraulic winches have a pulling capacity ranging from 3,000 to 10,000 Kg. The free drum control is located in the control panel on the operator's platform.



TRACKS

Caterpillar-type crawler undercarriages with triple grouser bars on industrial-grade shoes. A hydraulic cylinder controls the tensioning of the tracks, as on all earth-moving tractors.

ROLLERS

Pipe drive rollers are mounted on non-friction bearing and coated with 90 SH polyurethane for smoother handling of the pipe.

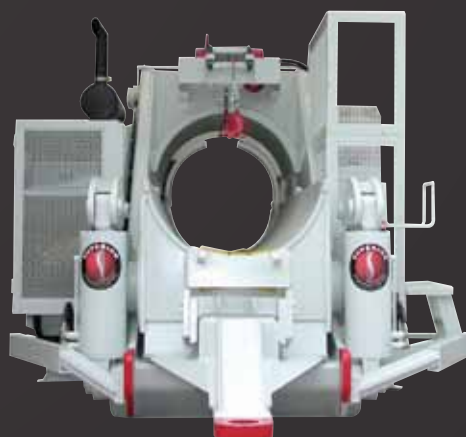

FRAME

The main frame is built with high quality steel plate and box-section design. This makes the machine stronger and more resistant to stresses, thus permitting bending of pipes with very high tensile strength.



BENDING DATA

U.S.

Pipe O.D. inch	Maximum Wall Thickness By Grade (Inch)							Recommended Bend		
	X52	X56	X60	X65	X70	X80	X100	Degree per Arc Foot	Radius Feet	Max Degree Per 40 Feet
32	2	2	2	2	2	1-3/4	1-5/16	0.58	99	14.50
34	2	2	2	1-7/8	1-3/4	1-1/2	1-1/8	0.55	104	13.75
36	2	1-15/16	1-3/4	1-5/8	1-1/2	1-5/16	1	0.50	115	12.50
38	1-13/16	1-11/16	1-9/16	1-7/16	1-5/16	1-1/8	7/8	0.50	115	12.50
40	1-5/8	1-1/2	1-3/8	1-1/4	1-1/8	1	13/16	0.50	115	12.50
42	1-7/16	1-5/16	1-3/16	1-1/8	1	7/8	11/16	0.50	115	12.50

METRIC

Pipe O.D. inch/mm	Maximum Wall Thickness By Grade (Inch)							Recommended Bend		
	X52	X56	X60	X65	X70	X80	X100	Ratio Radius: O.D.	Radius Meter	Max Degree Per 12 Meters
32 / 812.8	50.80	50.80	50.80	50.80	50.80	44.45	33.34	37.1	30.18	14.50
34 / 863.6	50.80	50.80	50.80	47.63	44.45	38.10	28.58	36.7	31.70	13.75
36 / 914.4	50.80	49.22	44.45	41.28	38.10	33.34	25.40	38.4	35.05	12.50
38 / 965.2	46.04	42.87	39.69	36.52	33.34	28.58	22.23	36.3	35.05	12.50
40 / 1016	41.28	38.10	34.93	31.75	28.58	25.40	20.64	34.5	35.05	12.50
42 / 1066.8	36.52	33.34	30.17	28.58	25.40	22.23	17.47	32.9	35.05	12.50

DIMENSIONS

Operating weight 95,900 lbs / 43,500 kg

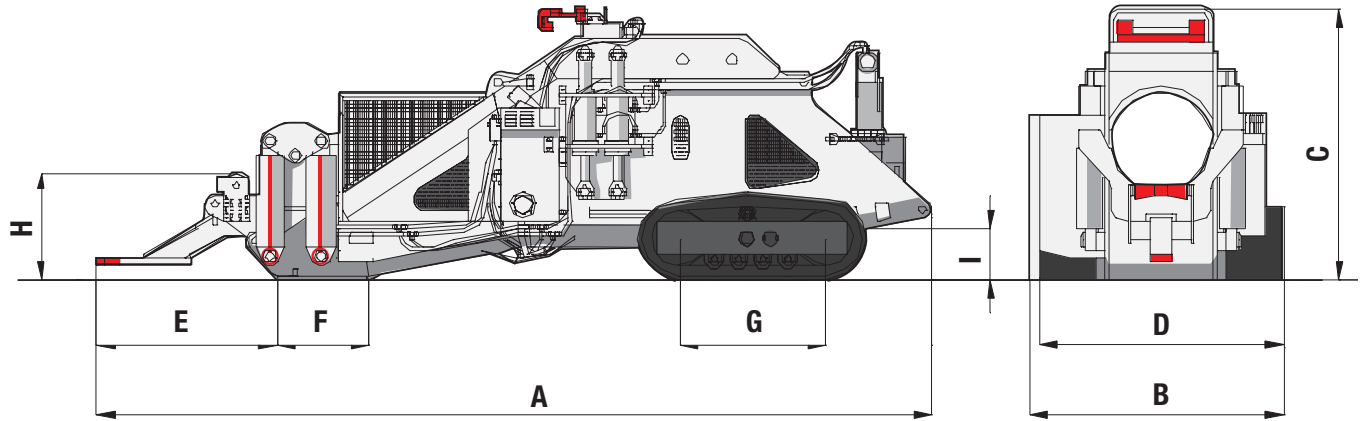

	<i>Feet</i>	<i>Meters</i>
A Overall length	29 ft	8.9 m
B Overall width	10.5 ft	3.25 m
C Height	10 ft	3 m
D Width to outside of tracks	10 ft	3 m
E Length of front section	6.5 ft	2 m
F Length of undercarriage touching the ground	4.4 ft	1.35 m
G Length of track on the ground	5 ft	1.5 m
H Height to top of roller	3.2 ft	1 m
I Ground clearance	1.2 ft	39 cm

Track weight (loose pair) 7,111 lbs / 3,200 kg

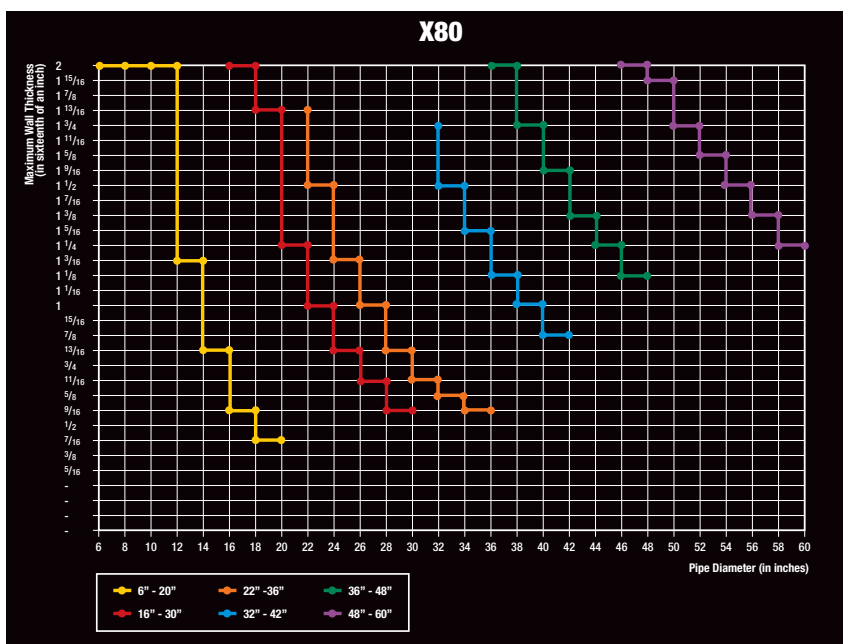

BENDING STRENGTH

Here's an example of our pipe bending machines high bending strength. The bending performance data shown was calculated using **API X80** as an example. The machine is capable of bending all grades of currently available API-5L pipe within its range.



AVAILABLE MODELS



SPB 6-20 Millennium Series



SPB 16-30 Millennium Series



SPB 22-36 Millennium Series



SPB 32-42 Millennium Series



SPB 36-48 Millennium Series



SPB 48-60 Millennium Series

CONTACT INFORMATION

Europe

Phone +49.0.231.963.3073

pipelinece@wwmach.com

Russia, China and the Middle East

Phone +39.349.198.1281 Italy

Phone +7.495.507.4827 Russia

fsupipeline@wwmach.com

India

Phone +91.11.414.59230

pipelineind@wwmach.com

Africa

Intl. Toll Free 800.9675.3948

pipeline@wwmach.com

North America

Phone +1.281.457.4400

pipelina@wwmach.com

Latin America

Phone +52.81.8.394.0160

pipelinesa@wwmach.com

Brazil

Phone 800.9675.3948

pipelinebr@wwmach.com

Australia

Phone +61.0.400.144.432

pipelinece@wwmach.com



16031 East Freeway

Houston, TX 77530

Phone 281.457.4400 Fax 281.452.5455

U.S. Toll Free 800.383.2666 Intl. Toll Free 800.9675.3948

pipeline@wwmach.com

www.worldwidemachinery.com