



SPW-D6M/N Welder Tractor

Operating weight	33,200 lbs / 15,050 kg
Boom capacity	5 ton and up
Net flywheel power	104 kW / 140 HP



SPW-D6M/N WELDER TRACTOR

ABOUT THE SPW-D6M WELDER TRACTORS

The SPW-D6M/N are based on a Caterpillar D6M or D6N in either XL or LGP variations. They are also available in any other D6 model variation and we offer an exceptional level of customization. From the knuckle boom, welding units, bottles, generators, etc., we can tailor-make them based on our customers' specific needs.

FEATURES

- Several knuckle booms from which to choose
- Custom-made platform for specific loadout
- As many welding units as required
- Several different packages available



GENERAL SPECIFICATIONS

ENGINE

Type	CATERPILLAR 3116 Turbocharge
Net flywheel power	140 HP
Governed speed	2,200 rpm

TRANSMISSION

Type	Power shift
Brakes	Oil cooled
1st gear	2.1 miles/h - 3.4 km/h
2nd gear	3.7 miles/h - 6 km/h
3rd gear	6.4 miles/h - 10.3 km/h

POWER TAKE-OFF

Type	Independent
Control	Power-shift

WELDER PACKAGES

Type welders (4)	Lincoln 400 amp
Type alternator	Marathon 125 Kw
Electrical outlets	220 and 110 V
Air compressor	Quincy 350/390
Displacement	27 CFM
Air tank	120 gallons
Powered by	10-20 HP electric motor

ELECTRIC SYSTEM

Operating voltage	24 V
Maintenance free supplied batteries	2
Capacity (total)	160 Ah
Starter capacity	7.5 Kw
Alternator	55 A

FLUID CAPACITIES

Fuel tank	311 liters - 82.2 U.S. gal
-----------	----------------------------

HYDRAULIC BOOM

Type	Hiab, Maxi-lift, Ferrari or custom fabricated
Operator controls	All are hydraulically controlled from cab
Maximum lifting capacity	5,000 lbs - 7,000 lbs
Optional: Type	Hiab 077
Max lifting capacity	5,952 lb - 2,700 kg (@ 2.3 m - 90.5 in)
Also available	Manual Jib Boom

GENERATOR

Type	Marathon generator (double bearing) 125 KW
Arrangement	Belt-driven; off of PTO
Alternate arrangement	Hydraulically driven generator
Voltage	110/220 variable outlets for grinding
or powers source	
Options	Can be adapted to 50/60 hertz

COMPRESSOR

Type	Quincy 350
Cubic feet per minute	28 CFM
Operating range	250 p.s.i.
Tank capacity	120 gal/liters
Options	Can be electrical or hydraulic driven

SPW-D6M FEATURES



HYDRAULIC BOOM

We have several brands of hydraulic booms from which to choose: Hiab, Maxilift or Bonfiglioli.



PACKAGES

The SPW-D6 Series can be outfitted with many different package combinations depending on the customer's needs, including power generators, welding units, gas tanks, electrical outlets, etc.



WELDING UNITS

The SPW-D6 series can be outfitted with as many welding units as the customer requires.



PLATFORM

High quality, custom platforms are built to accommodate the specific loadout of each machine.



DIMENSIONS

Operating weight 45,200 lbs / 20,500 kg

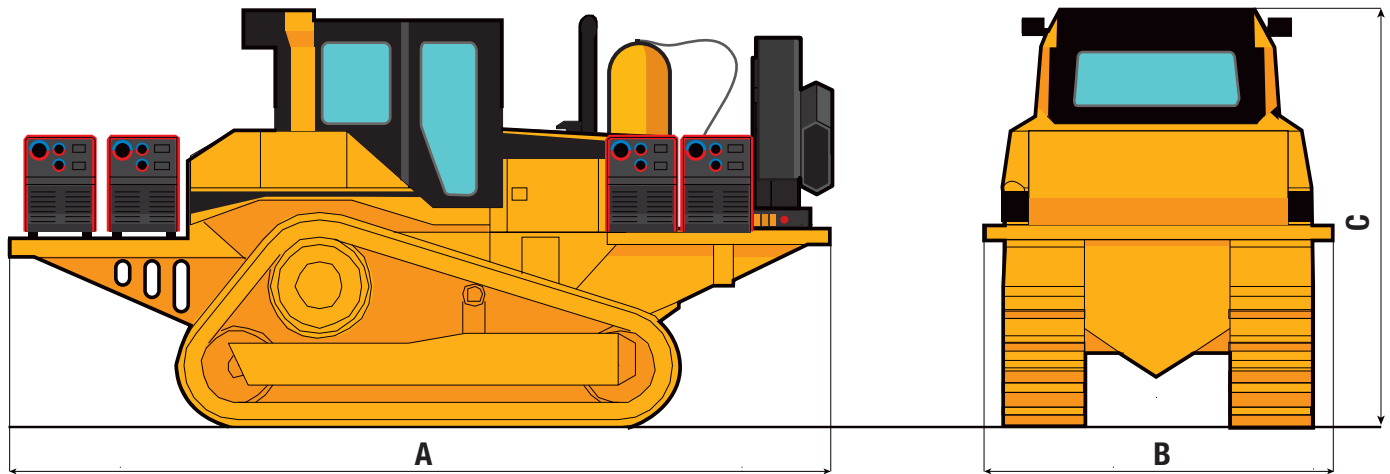

	Feet	Meters
A Overall length	22.4 ft	6.81 m
B Overall width	8.7 ft	2.65 m
C Overall height	11.6 ft	3.55 m

IMPORTANT: Because of the customized nature of these machines, these measurements are approximate and based on a standard load-out. Please inquire about measurements for a specific machine.

WELDING TENT

In addition to our line of welder tractors, we also have available a wide range of add-ons, consumables and accessories, such as welding tents.

The welding tents can be hooked and moved around via the welder tractor's knuckle boom and are a perfect solution to protect workers from inclement weather and ensure a more comfortable and safer work environment.

Contact us for more detailed information on this and other available accessories and consumables for your welding tractors.



AVAILABLE MODELS



SPW-D6D



SPW-D6E



SPW-D6M/N



SPW-D6R



SFT-180W

CONTACT INFORMATION

Europe

Phone +49.0.231.963.3073

pipelinece@wwmach.com

Russia, China and the Middle East

Phone +39.349.198.1281 Italy

Phone +7.495.507.4827 Russia

fsupipeline@wwmach.com

India

Phone +91.11.414.59230

pipelineind@wwmach.com

Africa

Intl. Toll Free 800.9675.3948

pipeline@wwmach.com

North America

Phone +1.281.457.4400

pipelina@wwmach.com

Latin America

Phone +52.81.8.394.0160

pipelinesa@wwmach.com

Brazil

Phone 800.9675.3948

pipelinebr@wwmach.com

Australia

Phone +61.0.400.144.432

pipelinece@wwmach.com

All information is subject to change without notice.



16031 East Freeway

Houston, TX 77530

Phone 281.457.4400 Fax 281.452.5455

U.S. Toll Free 800.383.2666 Intl. Toll Free 800.9675.3948

pipeline@wwmach.com

www.worldwidemachinery.com