

# TXD 1088

## 5.0 ton Tractor

### OVERVIEW

Used by the U.S. military for many years, these vehicles are considered the most sophisticated off-road, multi-purpose tactical vehicle in use, and are capable of operating anywhere in the world on primary and secondary roads, as well as on trails and cross-country in weather extremes from  $-50^{\circ}\text{F}$  ( $-46^{\circ}\text{C}$ ) to  $+120^{\circ}\text{F}$  ( $49^{\circ}\text{C}$ ).

### ENGINE OPTIONS

- Caterpillar C7
- Cummins ISB 2010
- CE compliant configuration available

### INCLINE GRADE

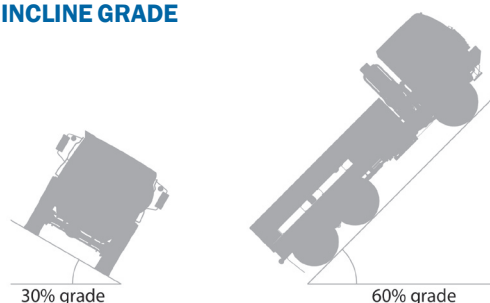

### KEY FEATURES

- Full-time all-wheel drive
- Fully automatic transmission
- Electronic Central Tire Inflation System (CTIS)
- Anti-lock Braking System (ABS)
- Interactive Electronic Technical Manuals (IETM)
- Fully MANPRINT compliant
- U.S. Army proven ultra-reliability
- Family of 16+ vehicles with 80% commonality
- U.S. Army certified 22-year corrosion protection
- Highest proven reliability of any tactical vehicle

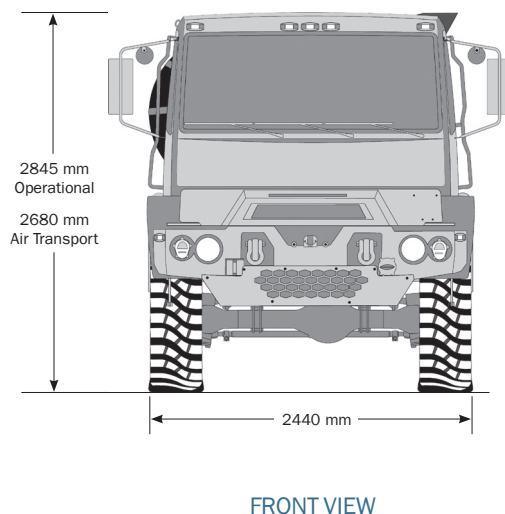
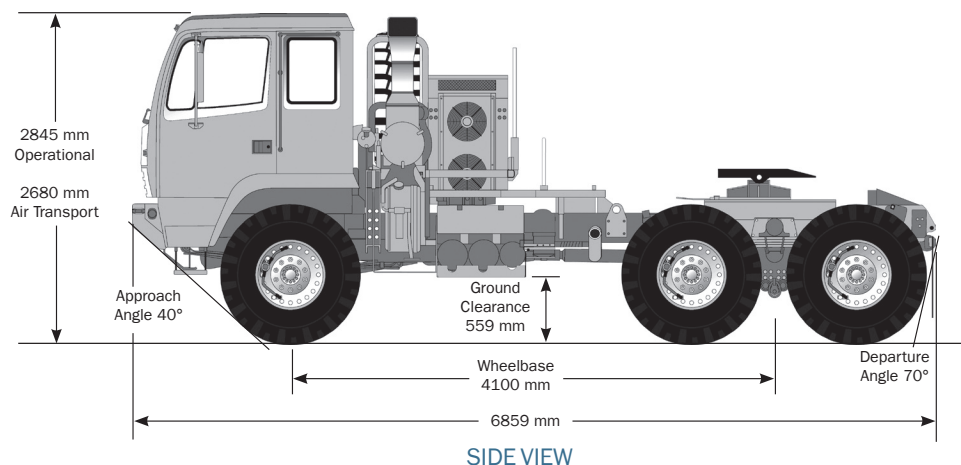

# TXD 1088

## 5.0 ton Tractor

### VEHICLE SPECIFICATIONS

Length:	270 in (6,859 mm)
Width:	96 in (2,438 mm)
Height:	
Operational	112 in (2,845 mm)
For Air Transport	105.5 in (2,680 mm)
Height–Pintle:	
Unloaded	36 in (905 mm)
With Payload	34 in (864 mm)
Height–5th Wheel:	
Unloaded	62.2 in (1,580 mm)
With Payload	58.4 in (1,484 mm)
Wheel Base:	161.4 in (4,100 mm)
Ground Clearance:	
Loaded	22 in (559 mm)
Under Axle	14.4 in (365 mm)
Approach/Departure Angle:	40°/70°
Vehicle Curb Weight with Fuel:	19,654 lb (8,915 kg)
Payload, 5th Wheel Vertical Load:	25,000 lb (11,340 kg) plus kits
Towed Load:	63,000 lb (28,576 kg)
Maximum Speed:	
Governed, at Gross Weight	58 mph (94 km/h)
Range, 78 gal (295 L) nominal:	300+ mi (483+ km)
Maximum Grade/Side Slope:	60%/30%
Turning Circle:	
Curb-to-Curb	65.6 ft (20.0 m)
Wall-to-Wall	69.6 ft (21.2 m)
Fording, without Kit:	30 in (762 mm)

### EQUIPMENT SPECIFICATIONS

Cab:	
Design	3-Man, Ergonomically Adjustable Driver Seat and Steering Wheel
Steering	Power Assisted, Recirculating Ball
Storage	8 cu ft
Suspension	3-Point Rubber Isolator
Engine:	
Caterpillar C7	Heavy Duty Diesel, 6-Cylinder, Electronic Controlled, Fuel-Injected Turbocharged and Aftercooled, EPA Certified
Rating	330 hp (246 kW) @ 2400 rpm
Displacement	441 cu in (7.2 L)
Torque	860 lb-ft (1,166 Nm) @ 1440 rpm
Fuel	Diesel, DF-2, JP-4, JP-8, VV-F-800
Oil	MIL-L-2104D, MIL-L-46167, 22 qt (21 L)
Transmission:	
Allison 3700SP	Automatic/Select 7-speed, Electronically Controlled
Full-Time All-Wheel Drive	Integral Transfer Case
Normal Operation	30% Torque Front Wheels, 70% Torque Rear Wheels; Off-Road, Equal Front and Rear
Oil	MIL-L-2104D, MIL-L-46167, 31.8 qt (30 L)
Axles:	
ArvinMeritor	Front, Intermediate and Rear Axles
Carrier	Single Reduction, Amboid-Gearing
Wheel End	Bevel Wheel End Reduction, Ratio 2:1
Overall Axle Gear Ratio	7.8:1
Front Axle Steering Angle	35°
Electrical:	
System	12/24 volt, EMI/HAEMP Qualified, Resettable Circuit Breakers, Central Power Distribution Panel, Battery and Charging Management System
Alternator	260 amp, 12/24 volt, Waterproof, EMI/RFI Suppressed
Starter	24 volt Waterproof
Instrumentation	SAE J1708 Data Bus Driven Instrument Cluster
Tires:	Goodyear 395/85R20 All-Terrain

Brakes:	
Primary	Dual-Circuit, Four Channel Air, Anti-Lock Braking System (ABS) with Trailers ABS Connectors for Emergency Towing
Supplemental	Air Actuated, Driver Controlled Exhaust Brake
Central Tire Inflation System, Eaton:	
	Cab-Mounted Electronic Controls, Operable while Driving Highway, Cross-Country, Air Transport, Sand/Mud/Snow, and Emergency Modes
Diagnostics, Interactive Electronic Technical Manuals (IETM):	
	Class V, Intrusive Diagnostics, SAE J1708/J1939 Data Buses to Diagnose All (4) Unique Electronic Control Modules (ECM)
Suspension:	
Front	Parabolic-Tapered Leaf Spring with Coil over Hydraulic Shock Absorbers
Rear	Tandem Axles with Parabolic-Tapered Leaf Spring with Hydraulic Shock Absorbers and Stabilizer Bar
Self Recovery Winch: (Optional)	15,500 lb (7,031 kg) Rating, 280 ft (85.3 m) Line Capacity, Fore/Aft Recovery Positions
Fifth Wheel:	
Holland-Siding	Full Oscillating, 36 in (914 mm) diameter, with Forks and Semi-automatic Lock for SAE J700 2.0 in (51mm) Kingpin
Vertical Load	25,000 lb (11,340 kg) Rating

### FOR MORE INFORMATION CONTACT:

Titan Trucks  
 16031 East Freeway  
 Houston, TX 77530  
 Telephone +1-281-457-4400  
 U.S. Toll Free +1-800-383-2666  
 Intl. Toll Free 800-9675-3948  
 Email titan@wwmach.com  
 www.worldwidemachinery.com

This document gives only a general description of the product(s) or services and except where expressly provided otherwise shall not form part of any contract. From time to time, changes may be made in the products or the conditions of supply. Titan Trucks reserves the right to change product specifications without prior notice.

© 2011 Titan Trucks All rights reserved.