

TXD 1148

9.0 ton Load Handling System

OVERVIEW

Used by the U.S. military for many years, these vehicles are considered the most sophisticated off-road, multi-purpose tactical vehicle in use, and are capable of operating anywhere in the world on primary and secondary roads, as well as on trails and cross-country in weather extremes from -50°F (-46°C) to +120°F (49°C).

ENGINE OPTIONS

- Caterpillar C7
- Cummins ISB 2010
- CE compliant configuration available

INCLINE GRADE

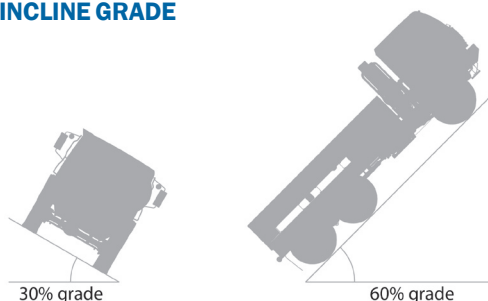

KEY FEATURES

- Full-time all-wheel drive
- Fully automatic transmission
- Electronic Central Tire Inflation System (CTIS)
- Anti-lock Braking System (ABS)
- Interactive Electronic Technical Manuals (IETM)
- Fully MANPRINT compliant
- U.S. Army proven ultra-reliability
- Family of 16+ vehicles with 80% commonality
- U.S. Army certified 22-year corrosion protection
- Highest proven reliability of any tactical vehicle

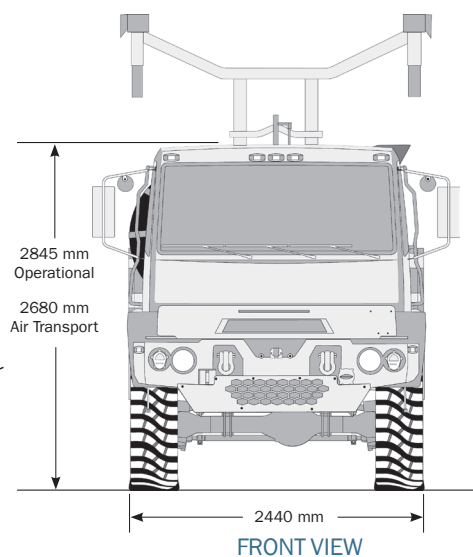
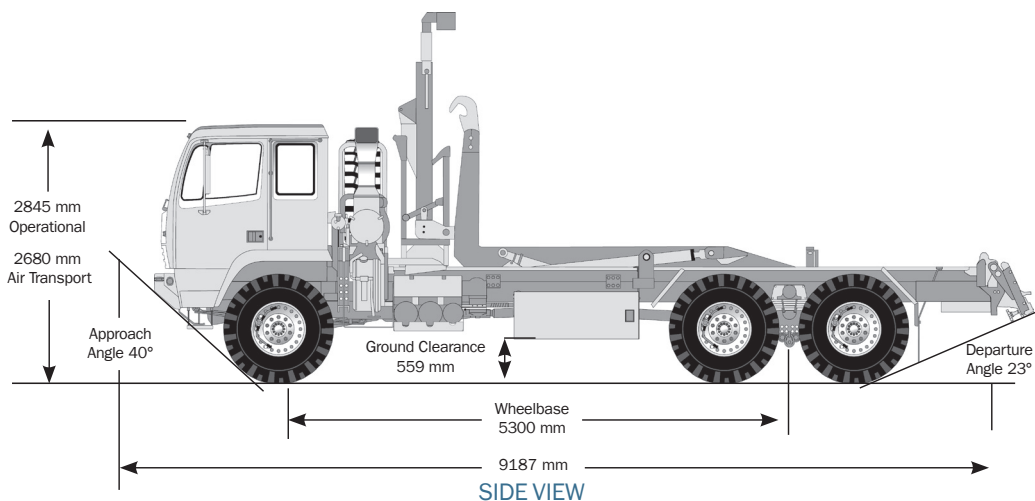

TXD 1148

9.0 ton Load Handling System

VEHICLE SPECIFICATIONS

Length:	361.7 in (9,187 mm)
Width:	96 in (2,438 mm)
Height:	
Operational	112 in (2,845 mm)
For Air Transport	105.5 in (2,680 mm)
Height-Pintle:	
Unloaded	36 in (905 mm)
With Payload	33 in (839 mm)
Wheel Base:	209 in (5,300 mm)
Ground Clearance:	
Loaded	22 in (559 mm)
Under Axle	14.4 in (365 mm)
Approach/Departure Angle:	40°/23°
Vehicle Curb Weight with Fuel:	25,049 lb (11,362 kg)
Payload, Lift Capacity:	17,640 lb (8,000 kg) plus kits
Towed Load, LHS Trailer:	27,117 lb (12,300 kg)
Maximum Speed:	
Governed, at Gross Weight	58 mph (94 km/h)
Range, 76 gal (295 L) nominal:	300+ mi (483+ km)
Maximum Grade/Side Slope:	60%/30%
Turning Circle:	
Curb-to-Curb	77 ft (23.5 m)
Wall-to-Wall	83 ft (25.3 m)
Fording, without Kit:	30 in (762 mm)

EQUIPMENT SPECIFICATIONS

Cab:	
Design	3-Man, Ergonomically Adjustable Driver Seat and Steering Wheel
Steering	Power Assisted, Recirculating Ball
Storage	8 cu ft
Suspension	3-Point Rubber Isolator
Engine:	
Caterpillar C7	Heavy Duty Diesel, 6-Cylinder, Electronic Controlled, Fuel-Injected Turbocharged and Aftercooled, EPA Certified
Rating	330 hp (246 kW) @ 2400 rpm
Displacement	441 cu in (7.2 L)
Torque	860 lb-ft (1,166 Nm) @ 1440 rpm
Fuel	Diesel, DF-2, JP-4, JP-8, VV-F-800
Oil	MIL-L-2104D, MIL-L-46167, 22 qt (21 L)
Transmission:	
Allison 3700SP	Automatic/Select 7-speed, Electronically Controlled
Full-Time	
All-Wheel Drive	Integral Transfer Case
Normal Operation	30% Torque Front Wheels, 70% Torque Rear Wheels; Off-Road, Equal Front and Rear
Oil	MIL-L-2104D, MIL-L-46167, 31.8 qt (30 L)
Axles:	
ArvinMeritor	Front, Intermediate and Rear Axles
Carrier	Single Reduction, Amboid-Gearing
Wheel End	Bevel Wheel End Reduction, Ratio 2:1
Overall Axle Gear Ratio	7.8:1
Front Axle Steering Angle	35°
Electrical:	
System	12/24 volt, EMI/HAEMP Qualified, Resettable Circuit Breakers, Central Power Distribution Panel, Battery and Charging Management System
Alternator	260 amp, 12/24 volt, Waterproof, EMI/RFI Suppressed
Starter	24 volt Waterproof
Instrumentation	SAE J1708 Data Bus Driven Instrument Cluster
Tires:	Michelin 395/85R20XML All-Terrain

Brakes:	
Primary	Dual-Circuit, Four Channel Air, Anti-Lock Braking System (ABS) with Trailers ABS Connectors for Emergency Towing
Supplemental	Air Actuated, Driver Controlled Exhaust Brake

Central Tire Inflation System, Eaton:
Cab-Mounted Electronic Controls, Operable while Driving Highway, Cross-Country, Air Transport, Sand/Mud/Snow, and Emergency Modes

Diagnostics, Interactive Electronic Technical Manuals (IETM):
Class V, Intrusive Diagnostics, SAE J1708/J1939 Data Buses to Diagnose All (4) Unique Electronic Control Modules (ECM)

Suspension:
Front Parabolic-Tapered Leaf Spring with Coil over Hydraulic Shock Absorbers
Rear Tandem Axles with Parabolic-Tapered Leaf Spring with Hydraulic Shock Absorbers and Stabilizer Bar

Self Recovery Winch:
(Optional) 15,500 lb (7,031 kg) Rating, 280 ft (85.3 m) Line Capacity, Fore/Aft Recovery Position

LHS Capabilities:
Load/Unload a 20 ft Container onto LHS or LHS Trailer;
Allow 157.5 in (4 m) Clearance with 8 ft x 8 ft x 20 ft (2.4 m x 2.4 m x 6.1 m) ISO Container Mounted Compatible with U.S. Army Flatracks (M1, M3, M1077); Automatically Guides, Centers, and Secures Flatrack; Lift Frame is Stowed on the Vehicle

FOR MORE INFORMATION CONTACT:

Titan Trucks
16031 East Freeway
Houston, TX 77530
Telephone +1-281-457-4400
U.S. Toll Free +1-800-383-2666
Intl. Toll Free 800-9675-3948
Email titan@wwmach.com
www.worldwidemachinery.com

This document gives only a general description of the product(s) or services and except where expressly provided otherwise shall not form part of any contract. From time to time, changes may be made in the products or the conditions of supply. Titan Trucks reserves the right to change product specifications without prior notice.

© 2011 Titan Trucks All rights reserved.